

**AVISON
YOUNG**



Professional spaces for lease

2395-2405 Drew Road & 7270 Torbram Road
Mississauga, ON



Get more information

Aidan Mallovy*

Principal

905 283 2396

aidan.mallovy@avisonyoung.com

Jordan Boin*

Principal

905 283 2372

jordan.boin@avisonyoung.com

Brooke Boquist*

Associate

905 283 2381

brooke.boquist@avisonyoung.com

Jordan Smith*

Senior Associate

905 283 2374

jordan.smith@avisonyoung.com

*Sales Representative

Property Details

2395-2405 Drew Road &
7270 Torbram Road
Mississauga, ON



Available Space

2395 Drew Road

Size	Asking Net Price	TMI (2024)
#5: 5,343 sf	\$18.75 psf net	\$5.96 psf

7270 Torbram Road

Size	Asking Net Price	TMI (2024)
#22-23: 3,443 sf	\$18.75 psf net	\$5.96 psf

Description

On the corner of Drew Road and Torbram Road, this Business Centre is a mixed-use complex located just east of Highways 403 and 410 and just north of Highway 401 and Toronto Pearson Airport.



Great access to public transit



Ample free parking



Professionally managed complex



Plenty of curb appeal



Quick access to Highways 401, 410 and 403



Well built-out offices with opportunity to reconfigure

Availabilities

2395-2405 Drew Road &
7270 Torbram Road
Mississauga, ON

2395 Drew Road

Industrial

Unit 5

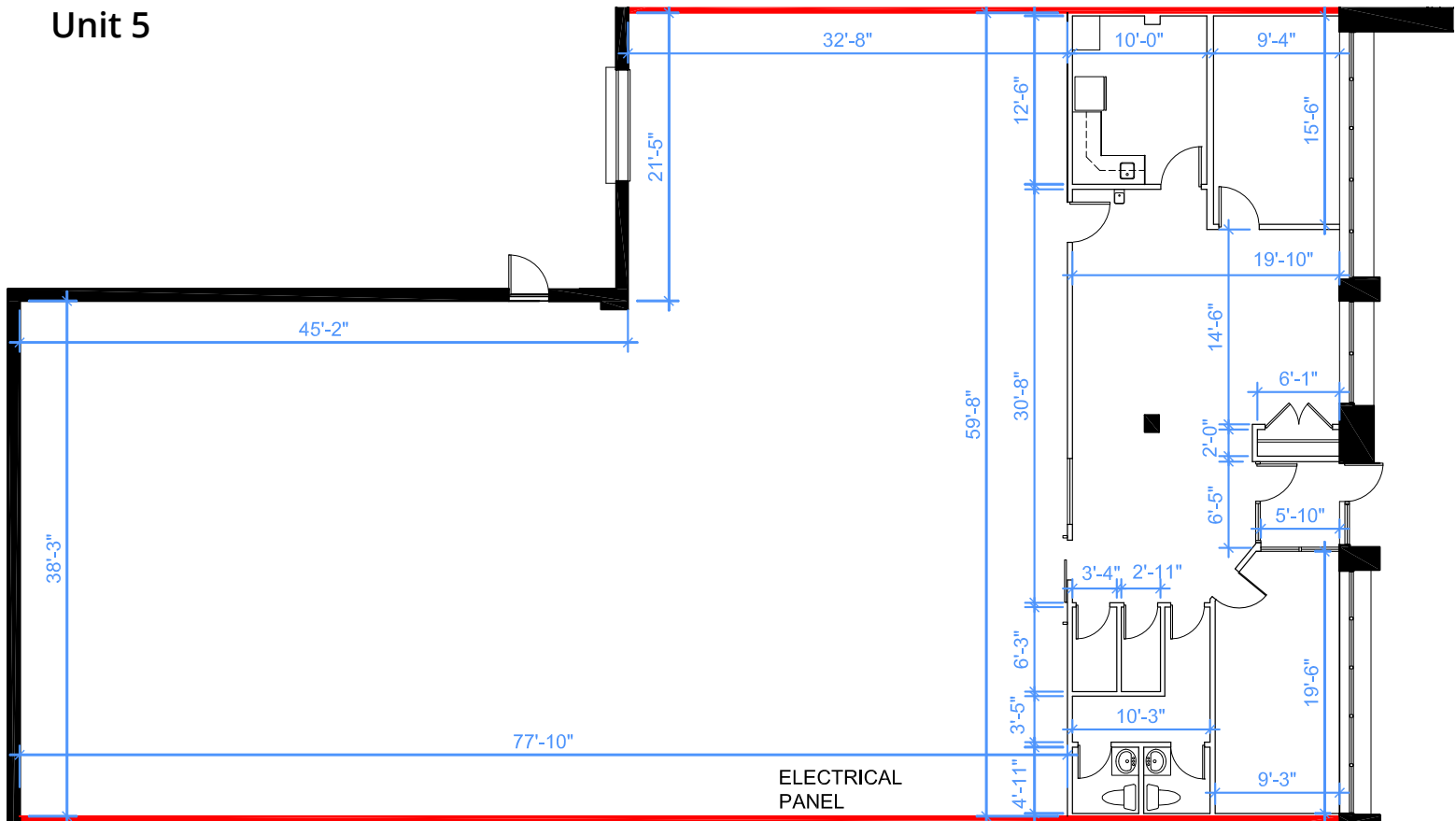

Unit(s)	Size	Office	Clear Height	Available	Asking Price	Comments
5	5,343 sf	27%	18'	June 1, 2024	\$18.75 psf net	<ul style="list-style-type: none"> - Functional and clean unit - Can accommodate 53' trailers - 1 truck level door

Availabilities

2395-2405 Drew Road &
7270 Torbram Road
Mississauga, ON

7270 Torbram Road

Industrial

Units 22-23

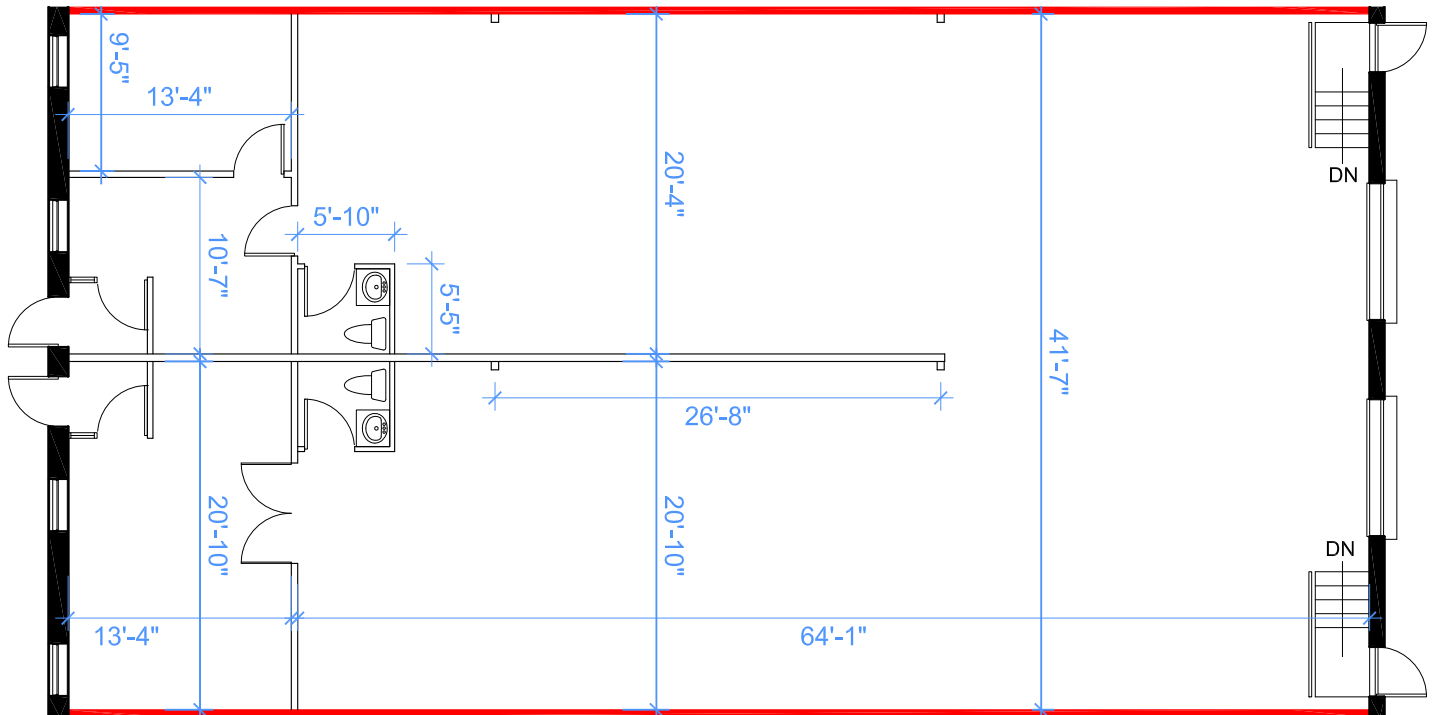

Unit(s)	Size	Office	Clear Height	Available	Asking Price	Comments
22-23	3,443 sf	20%	13'	September 1, 2024	\$18.75 psf net	<ul style="list-style-type: none"> - Functional and clean unit - Cannot accommodate 53' trailers - Maximum trailer size is 40' - 2 truck level doors

Transit & Amenities

2395-2405 Drew Road &
7270 Torbram Road
Mississauga, ON



PUBLIC TRANSIT



- 5 Dixie
- 15 Drew
- 16 Malton
- 24 Northwest
- 30 Woodbine
- 42 Derry
- 57 Courtneypark
- 74 Explorer
- 87 Meadowvale-Skymark
- 104 Derry Express
- 107 Malton Express

Join MiWay & Brampton Transit

- 185 Dixie

GO Train

Union Pearson Express



- 1 Queen
- 5 Bovaird
- 11 Steeles
- 13 Avondale
- 14 Torbram
- 15 Bramalea
- 16 Southgate
- 20 East Industrial
- 30 Airport Road
- 40 Central Industrial
- 501 Queen-York University
- 505 Bovaird-Malton GO
- 511 Steeles-Humber College

Distances from
2405-2421 Drew Road

4.5 km
to Toronto Airport

4.7 km
to Hwy 427

2.8 km
to Hwy 407

5.3 km
to Hwy 410

About the Landlord

2395-2405 Drew Road &
7270 Torbram Road
Mississauga, ON

Pure Industrial ("Pure") is one of Canada's leading providers of industrial real estate. Headquartered in Toronto, with offices in Montreal, Quebec City, and Vancouver, Pure owns and operates a 40+ million square foot portfolio of high-quality and well-located assets, ranging from small warehouses to large industrial developments.

Pure is strategically focused on developing and refining its unique industrial real estate offering in order to serve the needs of customers in locations critical to the Canadian supply chain, from the first mile to the last.

Pure prides itself on its professional and customer service-oriented team, and seeks to build long-term relationships with tenants by providing highly responsive and personalized service.

Get more information

Aidan Mallovy*

Principal
905 283 2396
aidan.mallovy@avisonyoung.com

Jordan Boin*

Principal
905 283 2372
jordan.boin@avisonyoung.com

Brooke Boquist*

Associate
905 283 2381
brooke.boquist@avisonyoung.com

Jordan Smith*

Senior Associate
905 283 2374
jordan.smith@avisonyoung.com

*Sales Representative

Avison Young Commercial Real Estate Services, LP, Brokerage
77 City Centre Drive, Suite 301, Mississauga, Ontario L5B 1M5
Office 905 712 2100 Fax 905 712 2937 avisonyoung.ca

© 2024, Avison Young. Information contained herein was obtained from sources deemed reliable and, while thought to be correct, have not been verified. Avison Young does not guarantee the accuracy or completeness of the information presented, nor assumes any responsibility or liability for any errors or omissions therein.

The Plans & Drawings are conceptual only and are subject to change without notice at the discretion of the Landlord.

